

STUDY GUIDE: VOLUME

First, **recall** the formula for area. For area, we have $A = l \times w$, or “Area equals length times width.” When we go from length to area, we multiply the new dimension, width. We do the exact same thing when we go from area to volume by adding height. In that case, we get the formula:

$$V = l \times w \times h$$

Or “Volume equals: length times width times height.” This also gives us a second formula by remembering that $l \times w$ equals A , area. We usually replace it with the letter B , standing for “Base,” but **area and base are THE SAME THING** in these equations.

$$V = A \times h$$

$$V = B \times h$$

So, how can we use these formulae? Well, if we know all three dimensions, we can find volume by multiplying. See the example below:

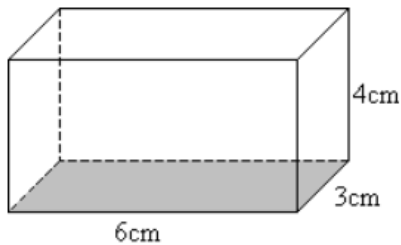

$$V = l \times w \times h$$

$$V = 6cm \times 3cm \times 4cm$$

$$V = 72cm^3$$

Notice that our final answer is in cm^3 , with a small three above the unit. This is called a **cubic unit**, or “units cubic.” In this case have centimeters cube, or “cubic cm” (cu cm). **All** volume answers should be cubic.

“But what if we don’t have one of the dimensions, like if I’m missing height?” This is not a problem if we know the volume – then we can find the missing height by using the formula $V = B \times h$!

This example has a **volume** of $600u^3$, or “ $V = 600u^3$.”

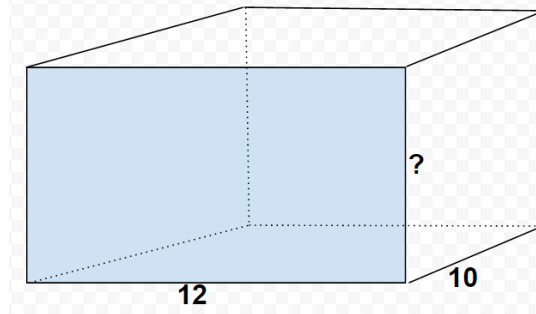

Well, we know the length and the height are 12 and 10, so...

$$V = B \times h$$

$$600u^3 = (12u \times 10u) \times h$$

$$600u^3 = 120u^2 \times h$$

When you reach this step, **divide the volume by the area** to get the height.

$$\frac{600u^3}{120u^2} = h$$

$$5u = h.$$

So our final answer is that our height is 5 units.

Your Turn

1. Find the volume.

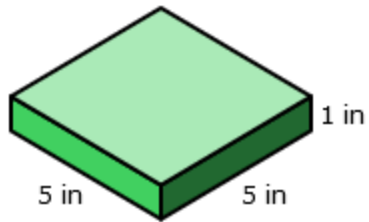

2. Find the volume.

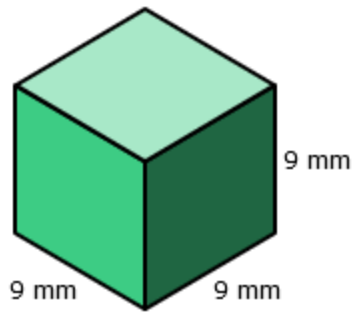

3. Find the volume.

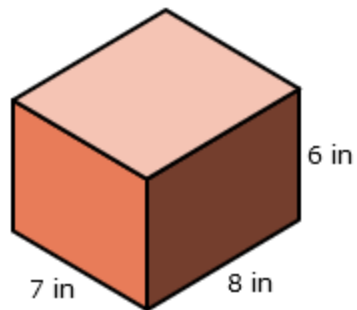

4. Find the volume.

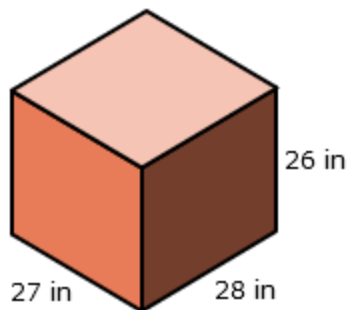

NAME: _____ DATE: _____ SECTION:5__

5. A rectangular prism is 7 inches long, 8 inches wide, and 6 inches high. What is the volume of the rectangular prism?

6. A rectangular prism is 7 inches long, 8 inches wide, and 6 inches high. What is the volume of the rectangular prism?

7. The side length of a cube is 8 inches. What is the volume of the cube?

8. The side length of a cube is 6.5 centimeters. What is the volume of the cube?

9. A rectangular prism has a length of $\frac{1}{2}u$, a width of $\frac{2}{5}u$, and a height of $2u$. What is the volume of this cube?

10. A rectangular prism has a volume of 48mm^3 , a length of 4cm, and a width of 3cm. What is the height of the rectangular prism?

11. A rectangular prism has a volume of 150mm^3 , a height of 10cm, and a width of 3cm. What is the length of the rectangular prism?

12. Find the volume of the compound figure.

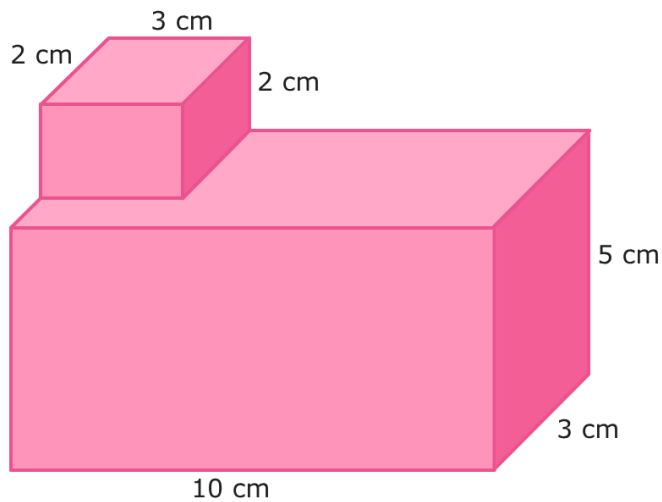

(Move to next page)

13. Find the volume of the compound figure.

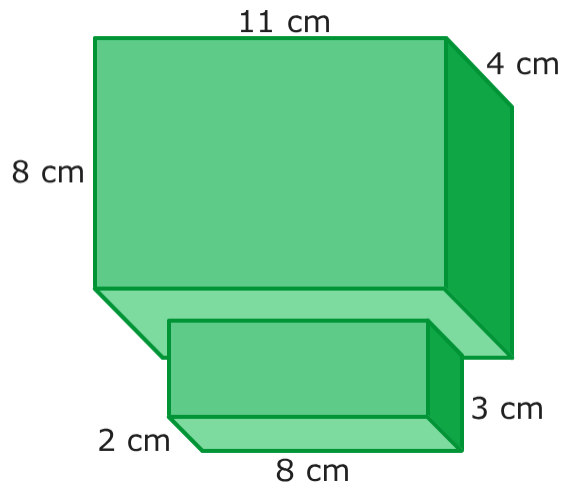

14. Find the volume of the compound figure.

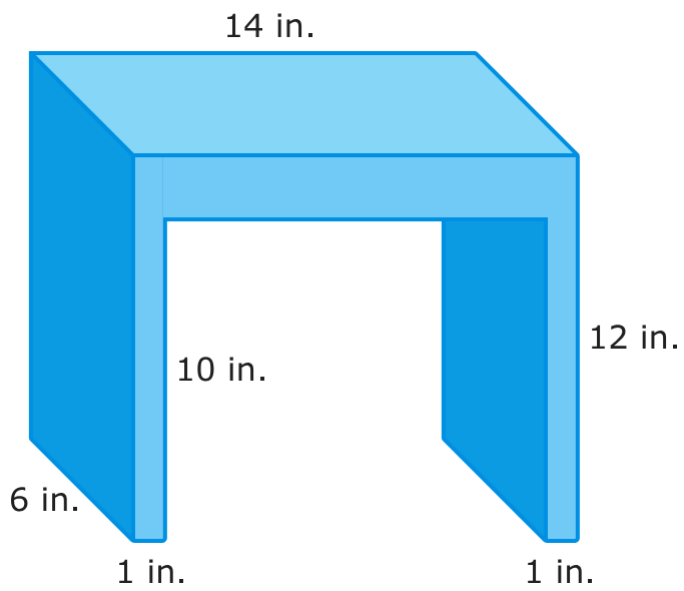

(Move to the next page.)

15. Theo fills a large shipping container with smaller boxes of staples. **Each** box of staples has a volume of 120cm^3 . What is (approximately) the total volume of the storage container?

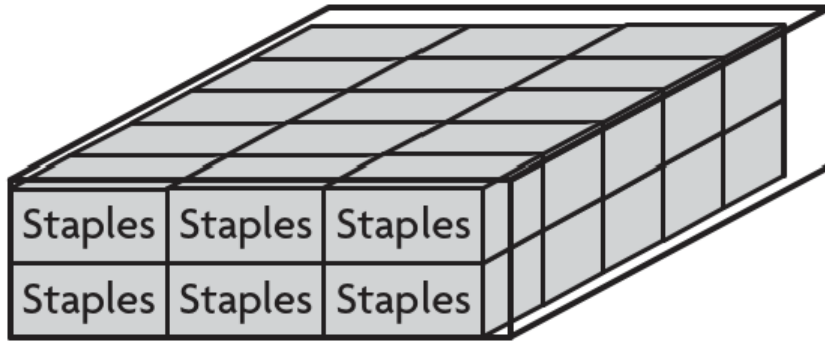

16. A box of greeting cards has a volume of 90in^3 . The box below is filled with boxes of greeting cards. What is (approximately) the volume of the larger box?

